



CAMBRIDGE ASSESSMENT

## BioMedical Admissions Test

4500/12

Wednesday

4<sup>th</sup> November 2009

30 minutes



### SECTION 2                      Scientific Knowledge and Applications

#### Instructions to Candidates

**Please read this page carefully, but do not open the question paper until you are told that you may do so.**

A separate answer sheet is provided for this section. Please check you have one. You also require a soft pencil and an eraser.

Please complete the answer sheet with your:

- BMAT candidate number
- centre number
- date of birth
- name

Speed as well as accuracy is important in this section. **Work quickly, or you may not finish the paper.** There are no penalties for incorrect responses, only points for correct answers, so you should attempt all 27 questions. All questions are worth one mark.

Answer on the sheet provided. Most questions ask you to show your choice between options by shading a circle. If questions ask you to write in words or numbers, be sure to write clearly in the spaces provided. If you make a mistake, erase thoroughly and try again.

Any rough work should be done on this question paper.

Calculators are NOT permitted.

**Please wait to be told you may begin before turning this page.**

*This paper consists of 18 printed pages and 2 blank pages.*

**BLANK PAGE**

- 1 Individual A in the family pedigree below is homozygous dominant and individual B is homozygous recessive for a particular feature.

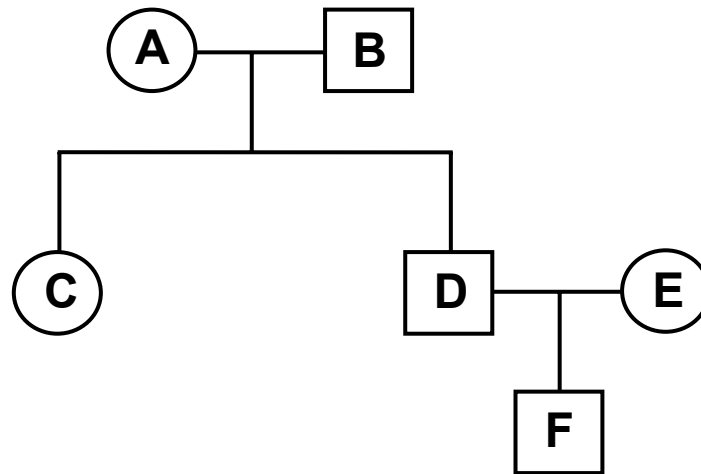

What is the percentage probability that individual F is homozygous recessive if:

	i) E is homozygous recessive	ii) E is heterozygous
A	50	0
B	25	50
C	50	25
D	25	0
E	0	25

2 Which of the following could take part in an addition polymerisation?

- 1  $\text{CHI}_3$
- 2  $\text{C}_{24}\text{H}_{48}$
- 3  $\text{C}_3\text{H}_7\text{Br}$
- 4  $\text{C}_4\text{H}_6\text{Cl}_2$
- 5  $\text{C}_8\text{H}_{12}\text{Cl}_4$

- A 1, 2 and 3
- B 1, 2 and 4
- C 1, 3 and 5
- D 2, 3 and 4
- E 2, 4 and 5
- F 3, 4 and 5

- 3 Shortly after opening her parachute, a free-fall parachutist of mass 60kg experiences the forces shown in the diagram.

drag (air resistance) = 900N

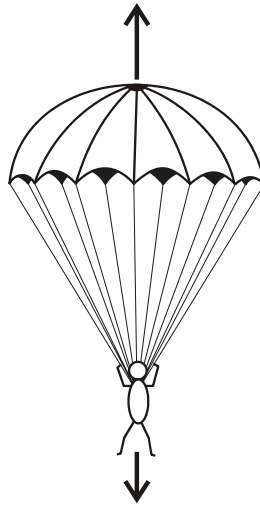

weight = 600N

Which line in the table gives the size and direction of the acceleration of the parachutist at this instance?

	size of acceleration ( $\text{m/s}^2$ )	direction of acceleration
<b>A</b>	5.0	downwards
<b>B</b>	10.0	downwards
<b>C</b>	5.0	upwards
<b>D</b>	10.0	upwards
<b>E</b>	0.0	-

- 4 A bag contains  $x$  red balls,  $y$  blue balls and  $z$  yellow balls. One ball at random is taken out and replaced. A second ball at random is taken out and replaced.

If the balls are identical in all respects except colour and are well mixed, what is the probability that the first ball was red and the second blue?

- A  $(x+y)/(x+y+z)^2$   
B  $xy/(x+y+z)(x+z)$   
C  $xy/(x+y+z)^2$   
D  $(x+y)/(x+y+z)$   
E  $xy/(y+z)(x+z)$

- 5 Which one of the following statements is true about the members of a clone?

- A Members of a clone will always show identical features at maturity.  
B Multiple births, such as twins, are always members of a clone.  
C They are produced only during genetic engineering.  
D They are the result of a mutation.  
E They contain identical DNA.

- 6 Which one of the following covalent substances could exist as a giant structure?

- A  $\text{SiCl}_4$   
B  $\text{SiO}_2$   
C  $\text{ICl}$   
D  $\text{Cl}_2\text{O}$   
E  $\text{H}_2\text{S}$   
F  $\text{CF}_4$

7 Which of the following is a correct unit of potential difference (voltage)?

- A amp per ohm
- B coulomb per joule
- C joule per second
- D newton per coulomb
- E watt per amp

8 A cube has unit length sides. What is the length of a line joining a vertex to the midpoint of one of the opposite faces (the dashed line in the diagram below)?

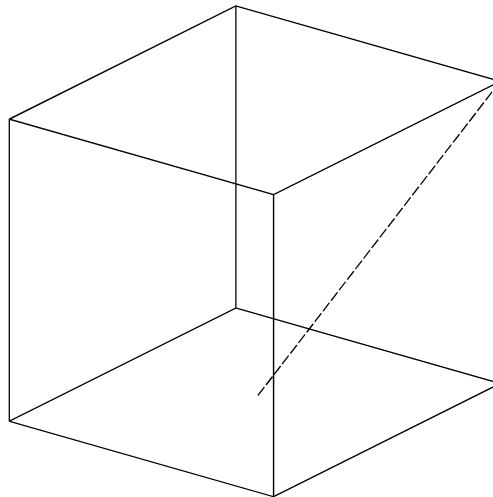

- A  $\sqrt{2}$
- B  $\sqrt{\frac{3}{2}}$
- C  $\sqrt{\frac{5}{2}}$
- D  $\sqrt{3}$
- E  $\sqrt{5}$

- 9 The data below considers the risk of having a cancer in the neck region due to drinking alcohol and one genetic factor (presence of a mutant allele for the CYP1A1 gene). A risk value of 1.0 is the mean average risk in the human population.

Alcohol intake	Number of mutant CYP1A1 alleles present	Risk value
Light drinker	0	1.0
	1	1.5
	2	1.8
Heavy drinker	0	4.0
	1	4.5
	2	6.0

Using only the data from the table, which of the following tentative conclusions about the risk of having a cancer of the neck, is **not** correct?

- A** Overall, the presence of at least one mutant allele increases the risk.
- B** Overall, there is a positive correlation between the risk and alcohol intake.
- C** Heavy drinking is the main factor in increasing the risk.
- D** The presence of at least one mutant allele is the main factor for increasing risk.
- E** The presence of two mutant alleles increases the risk more for heavy drinkers than light drinkers.
- 10 2.00g of a carbon compound is burnt in excess oxygen.

4.77g of carbon dioxide is produced.

What percentage (to the nearest 1%) of carbon is in the original compound?

[ $A_r$ : C=12; O=16]

- A** 21%
- B** 26%
- C** 42%
- D** 52%
- E** 65%



- 11 It is known that a radioactive source emits a single type of radiation. Detectors are placed in the two positions shown. The graph shows how the readings change over time.

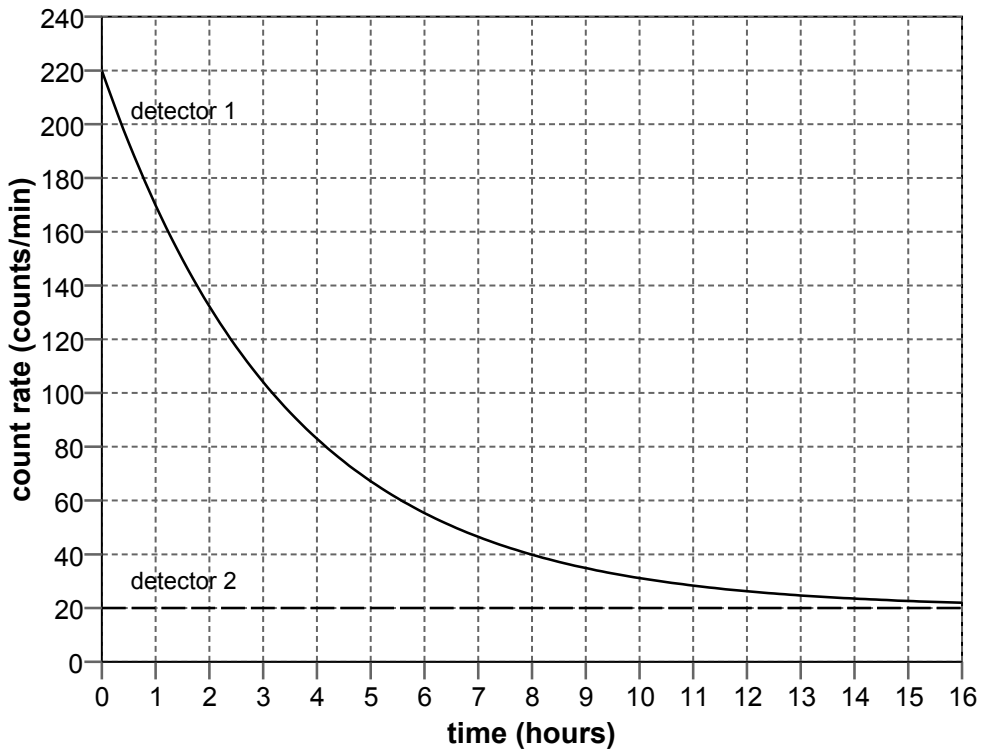
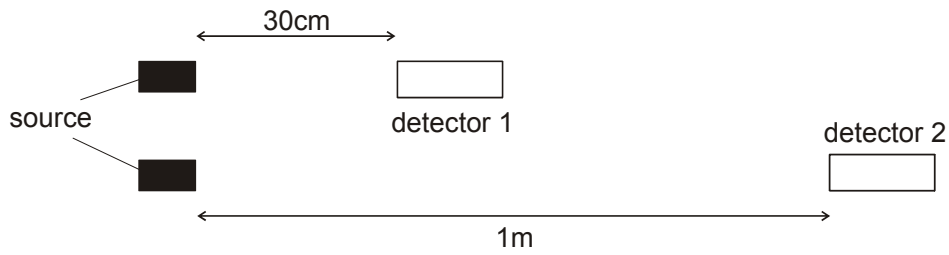

Which type of radiation does the source emit, and what is its half-life?

	type of radiation	half-life (hours)
A	alpha	2.40
B	alpha	2.76
C	beta	2.40
D	beta	2.76
E	gamma	2.40
F	gamma	2.76

- 12 The symbol  $\diamond$  defines a mathematical binary operation such that  $y \diamond x = \frac{y^x}{x}$  for all positive integers.

What is the value of  $(2 \diamond 3) \diamond 2$ ?

- A  $2 \times 3^3$
- B  $8/3$
- C  $32/9$
- D 4
- E  $2^5 \sqrt{2}/9$
- 13 Which one of the following movements will be severely and immediately disrupted if the oxygen concentration in the blood becomes very low?
- A carbon dioxide from the blood into the alveoli
- B glucose from the lumen of the intestine into the villi
- C oxygen from the alveoli into the blood
- D urea from the blood plasma into the nephron
- E water from the blood plasma into muscle cells
- F water from the blood plasma into the nephron

- 14 The order of reactivity of four elements is  $J > M > Q > T$  i.e. J is the most reactive and T the least reactive.

A series of reactions are given below:

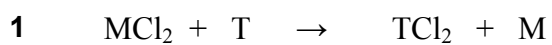

Which three reactions could take place?

- A 1, 2 and 3  
B 2, 3 and 4  
C 4, 5 and 6  
D 1, 4 and 6

15 The graph represents the motion of a vehicle during part of a journey.

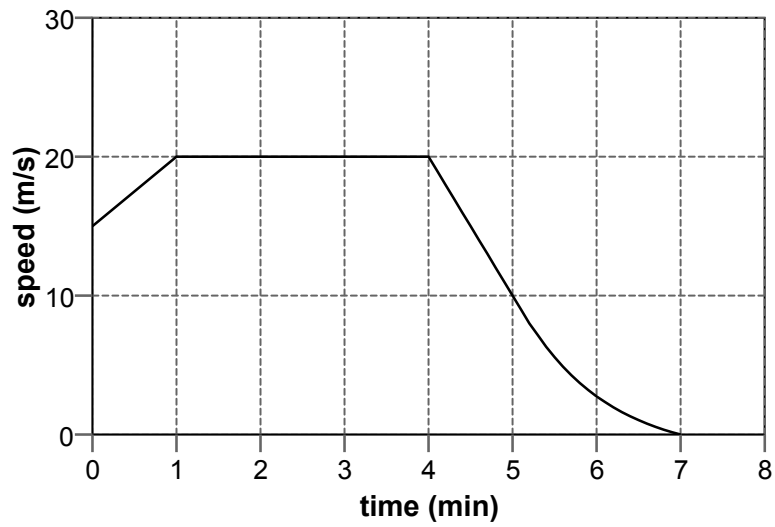

What is the best estimate of the distance travelled during the part of the journey shown?

- A 100.00m
- B 107.50m
- C 115.00m
- D 6.00km
- E 6.45km
- F 6.90km

16 Evaluate:

$$\sqrt{\left(\frac{2 \times 10^3 + 8 \times 10^2}{\frac{1}{2500} + 3 \times 10^{-4}}\right)}$$

- A            20  
 B            140  
 C            200  
 D            625  
 E            1700  
 F            2000  
 G            20000

17 Which of the four statements below about natural selection are correct?

- 1      Competition occurs between individuals of the same species.
- 2      Competition occurs between individuals of different species.
- 3      Selection can lead to evolution.
- 4      Selection can lead to extinction.

- A      1 and 3 only  
 B      2 and 4 only  
 C      1, 2 and 4 only  
 D      1, 3 and 4 only  
 E      2, 3 and 4 only  
 F      All of the above

18 The equation for the preparation of nitrogen monoxide is:



What is the value of **b**?

- A 2
- B 4
- C 6
- D 8
- E 12
- F 16

19 An object of mass 5kg falls from rest and hits the ground at a speed of 20m/s. Air resistance is negligible.

From what height has the object fallen?

Take  $g$  to be  $10\text{m/s}^2$

- A 10m
- B 20m
- C 50m
- D 100m
- E 200m
- F 1000m

- 20 A solid sphere of radius  $r$  fits inside a hollow cylinder. The cylinder has the same internal diameter and length as the diameter of the sphere.

The volume of a sphere is  $\frac{4}{3}\pi r^3$ , where  $r$  is the radius of the sphere.

What fraction of the space inside the cylinder is taken up by the sphere?

- A  $\frac{1}{4}$   
 B  $\frac{1}{3}$   
 C  $\frac{1}{2}$   
 D  $\frac{2}{3}$   
 E  $\frac{3}{4}$

- 21 The diagram shows a section through an alveolus. Gases diffuse through the alveolar and capillary walls.

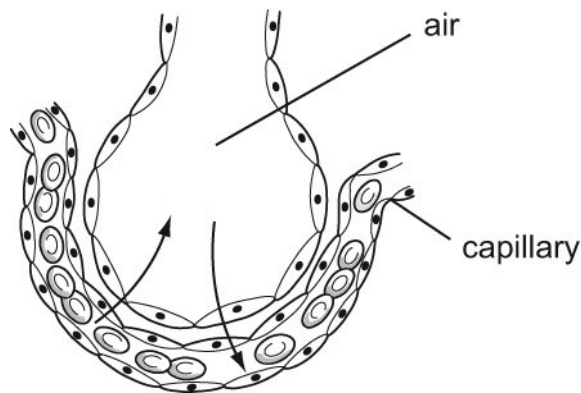

Which row explains why gaseous exchange occurs in the alveolus?

	Concentration of:			
	oxygen in alveolus	oxygen in capillary	carbon dioxide in alveolus	carbon dioxide in capillary
A	high	low	high	low
B	low	high	low	high
C	high	high	high	low
D	high	low	low	high
E	low	high	high	low
F	low	low	low	high

- 22 At room temperature, a reaction is very fast if no bonds are broken while it takes place, and is slow if bonds have to be broken.

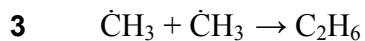
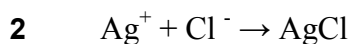
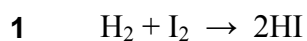

Which of the following are the two fastest reactions?

- A 1 and 2  
 B 1 and 3  
 C 1 and 4  
 D 2 and 3  
 E 2 and 4  
 F 3 and 4

- 23 A train consists of a powered engine pulling two unpowered carriages.

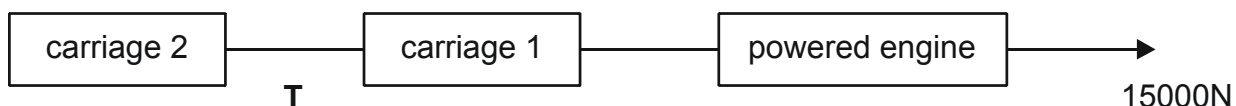

The engine has a mass of 20000kg, and each carriage has a mass of 5000kg. When the engine accelerates from rest it develops a thrust (driving force) of 15000N as shown.

Ignoring resistive forces, what is the tension (pulling force) **T** in the coupling between carriage 1 and carriage 2?

- A 2500N  
 B 3750N  
 C 5000N  
 D 7500N  
 E 15000N



24 The equation gives  $y$  in terms of  $x$ .

$$y = 5\left(\frac{x}{2} - 3\right)^2 - 10$$

Rearrange the equation to give an expression for  $x$  in terms of  $y$ .

- A**  $\pm 2\sqrt{\frac{y+10}{5}} + 6$
- B**  $\pm 2\sqrt{\frac{y+10}{5}} - 6$
- C**  $\pm 2\sqrt{\frac{y-10}{5}} + 6$
- D**  $\pm 2\sqrt{\frac{y-10}{5}} - 6$
- E**  $\pm 2\sqrt{\frac{y+50}{5}} + 6$
- F**  $\pm 2\sqrt{\frac{y+10}{5}} + 3$

25 The following five statements relate to homeostasis (the maintenance of stable internal conditions of the body):

- 1 Insulin helps to control the water content of the body.
- 2 Homeostasis depends only on hormones.
- 3 The pancreas helps to control the glucose content of the blood.
- 4 Both the nervous and hormonal systems are involved in homeostasis.
- 5 The skin is used to help control the body temperature.

Which statements are correct?

- A 1, 2 and 3 only
- B 1, 3 and 4 only
- C 1, 4 and 5 only
- D 2, 3 and 5 only
- E 2, 4 and 5 only
- F 3, 4 and 5 only

26 Naturally occurring chlorine is a mixture of two isotopes with mass number 35 and 37. The isotope with mass number 35 is three times as common as the isotope with mass number 37. Naturally occurring bromine is a mixture of two isotopes with mass numbers 79 and 81. They are present in equal amounts.

What fraction of the naturally occurring compound  $\text{CH}_2\text{BrCl}$  has a relative molecular mass of 128?

[ $A_r$ : H = 1; C = 12]

- A  $\frac{1}{8}$
- B  $\frac{1}{4}$
- C  $\frac{3}{8}$
- D  $\frac{1}{2}$
- E  $\frac{5}{8}$

- 27 The first graph shows the variation of the displacement of particles with distance along a wave at a particular instant in time:

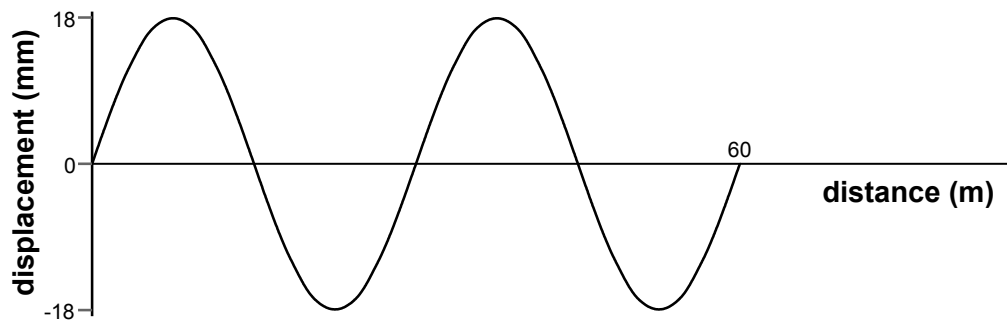

The second graph shows the variation with time of the displacement of a particular particle in this wave:

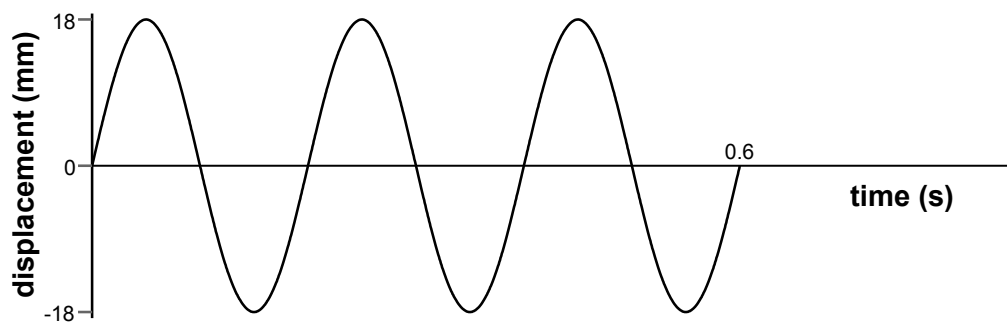

What is the speed of this wave?

- A 30m/s
- B 50m/s
- C 90m/s
- D 100m/s
- E 150m/s
- F 300m/s

**BLANK PAGE**